

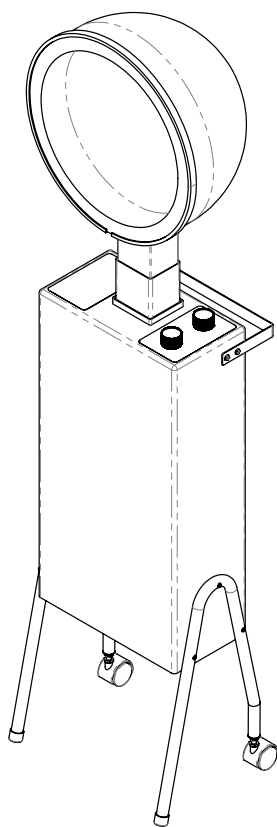

LANVAIN



Casque séchoir / Hooded Dryer

ZEPHYR

UGS : 1500

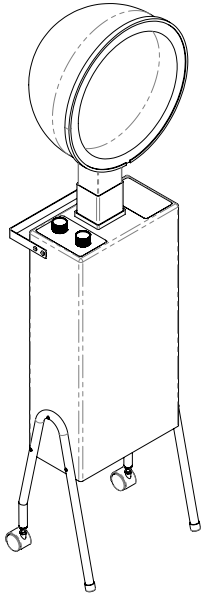

Features:

- UL/CSA approved
- 100 Watt Convenience Outlet
- Adjustable Thermostat including Perm Setting
- Electronic 60-Minute Timer with Cool Down Period
- All-Lexan Smoked Jumbo Inner & Outer Hoods
- Removable Air Filter
- Dryer Leg and Handle Sets Available as Accessory
- Made in USA

Dimensions:

Cabinet: 12-1/4" W x 23-3/4" H x 6-1/2" D
Hood: 12-1/4" (inside diameter)

Air Velocity:

375 / 400 CFM

Electrical Rating:

UL and CSA Approved
120 VAC, 60 Cycle, 8.0 Amps (without Convenience Outlet)
120 VAC, 60 Cycle, 9.7Amps (with Convenience Outlet)

Heat Output:

(Tested at 118 Volts, 8-8.5 Amps, 980 Watts)

<u>Thermostat Setting</u>	<u>Temperature</u>
Low	85° to 90°
Medium	98° to 110°
Perm	140° plus

BTU / Hour = 3334



Dimensions (pouces / inches)

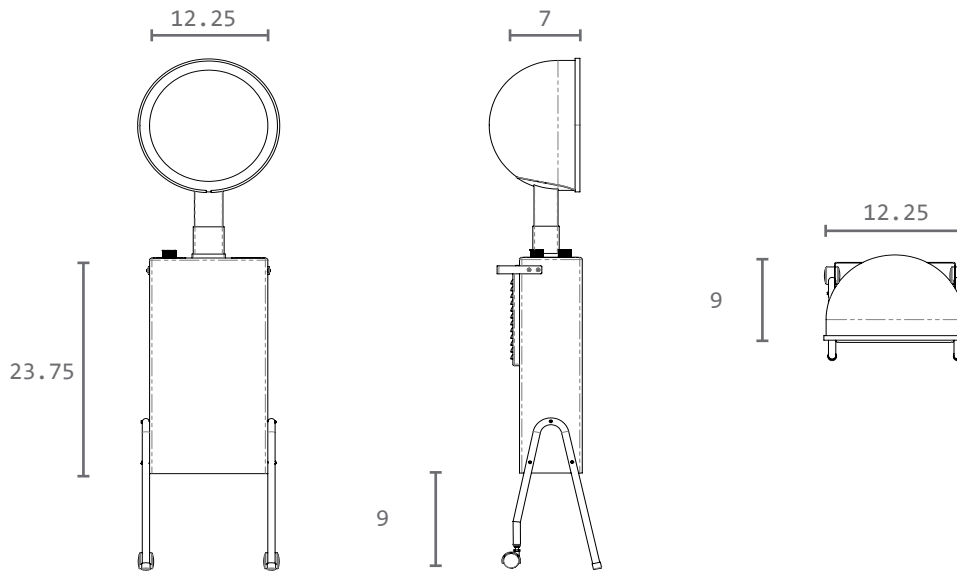

Dans les boîte / In the boxes

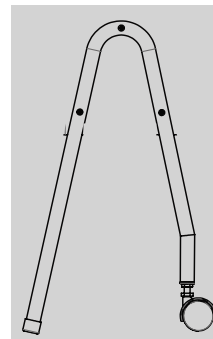
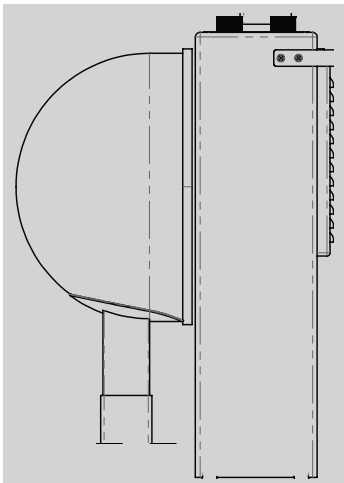

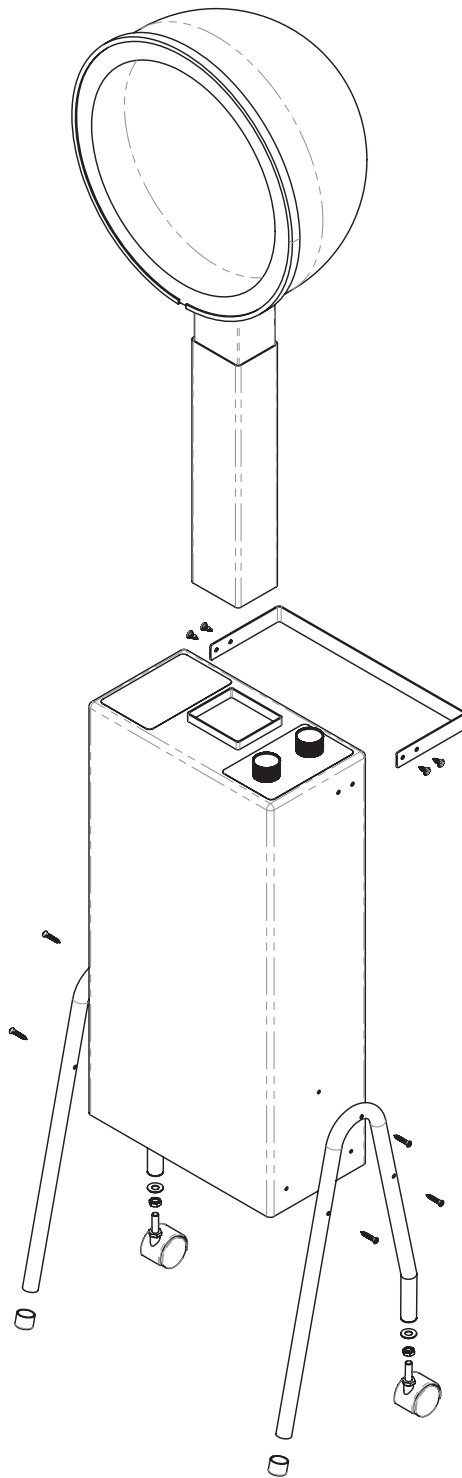

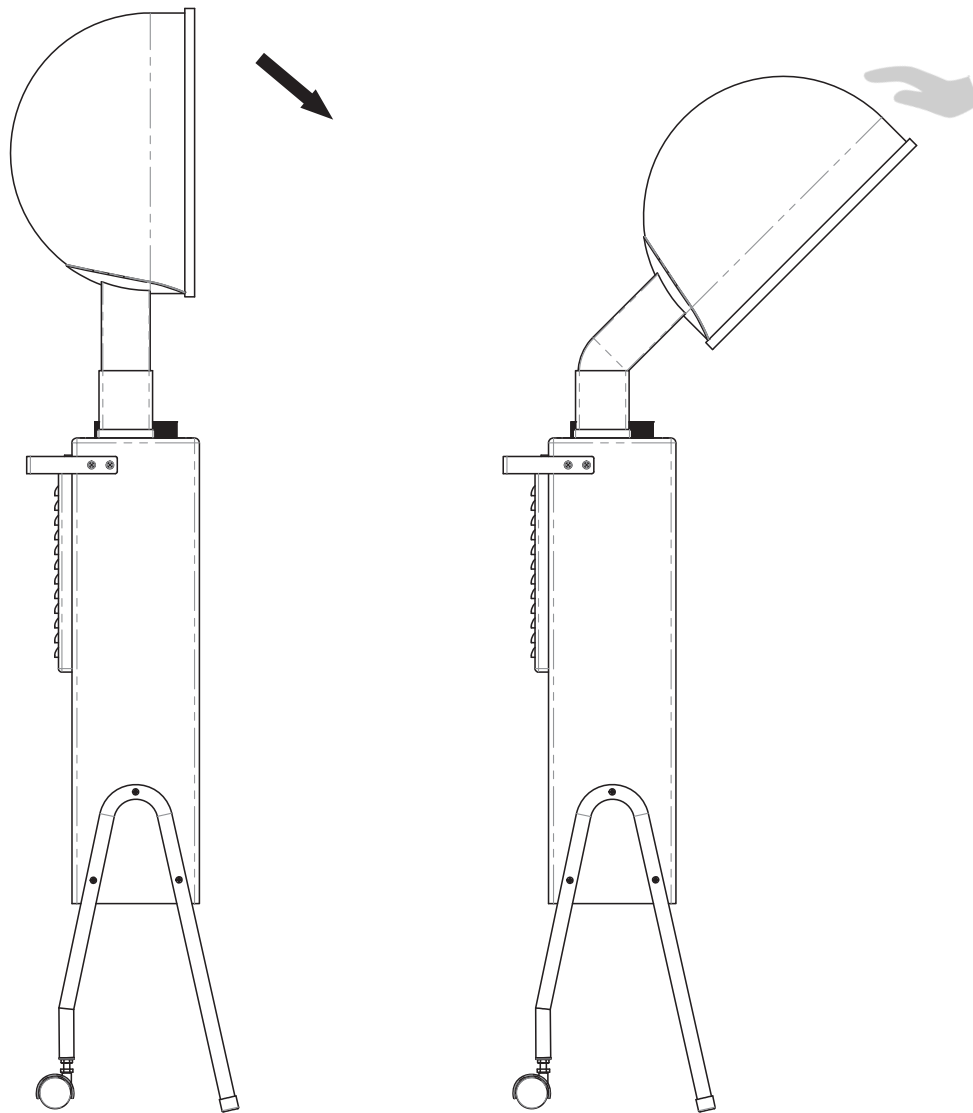

Composantes / Components

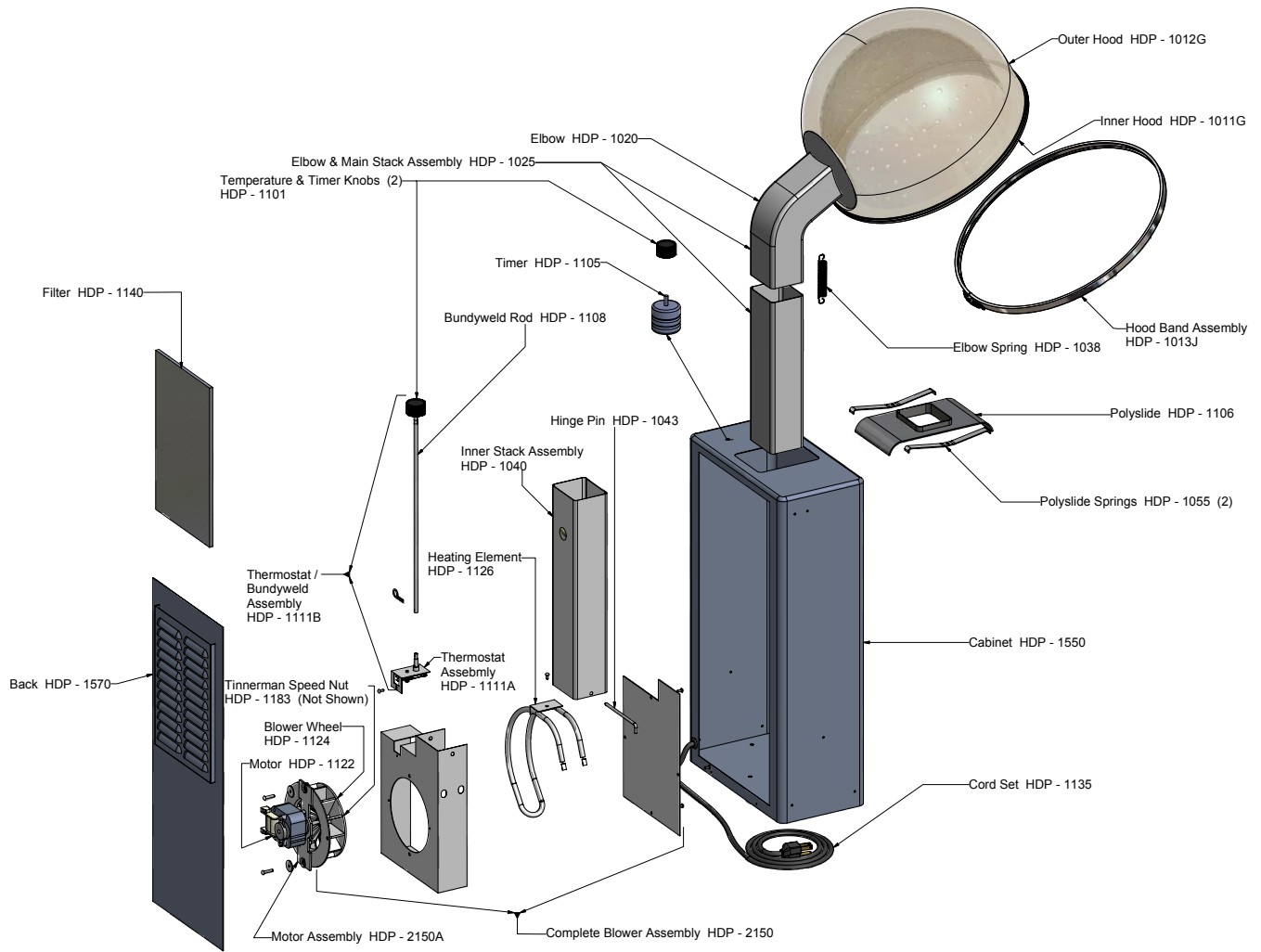

Certification



Underwriters
Laboratories

File E50555

Vol 1

Issued: 1971-11-24

Revised: 2009-06-05

FOLLOW-UP SERVICE PROCEDURE
(TYPE R)

PERSONAL GROOMING APPLIANCES, COMMERCIAL
(QGRT, QGRT7)

This Procedure authorizes the above manufacturer to use the marking specified by Underwriters Laboratories Inc. (UL), or any authorized licensee of UL, only on products covered by this Procedure, in accordance with the applicable UL Services Agreement.

The prescribed Mark or Marking shall be used only at the above manufacturing location on such products which comply with this Procedure and any other applicable requirements.

The Procedure contains information for the use of the above named Manufacturer and representatives of Underwriters Laboratories Inc. and is not to be used for any other purpose. It is lent to the Manufacturer with the understanding that it is not to be copied, either wholly or in part, and that it will be returned to Underwriters Laboratories Inc. (UL) or any authorized licensee of UL, upon request.

This PROCEDURE, and any subsequent revision, is the property of Underwriters Laboratories Inc. (UL) and the authorized licensee of UL and is not transferable.

Underwriters Laboratories Inc.

Stephen Hewson
Senior Vice President
Global Follow-Up Service Operations

William R. Carney
Director
North American Certification Program





LANVAIN

WHEN ONLY THE BEST WILL DO