

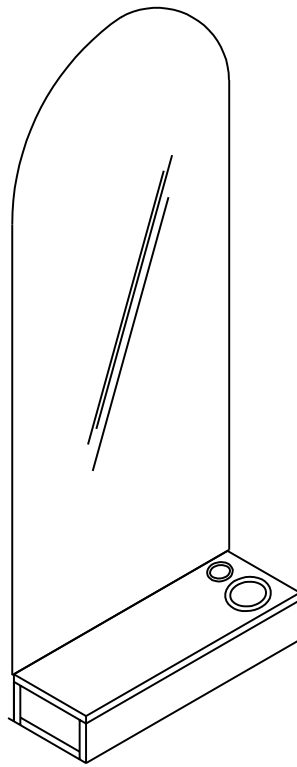

LANVAIN



Station de Coiffure / Styling Station



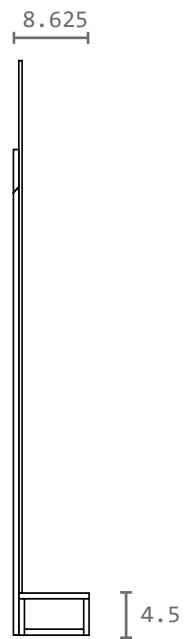
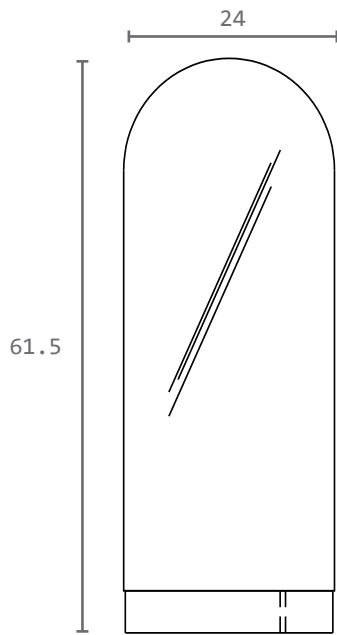

DAHLIA

UGS : SS2

Dimensions (pouces / inches)

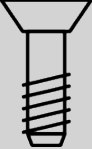

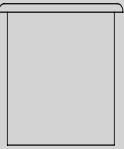
Quincaillerie / Hardware

A	B	C	D	E
				
X 6	X 4	X 4	X 1	X 1



Dans le salon / In the salon

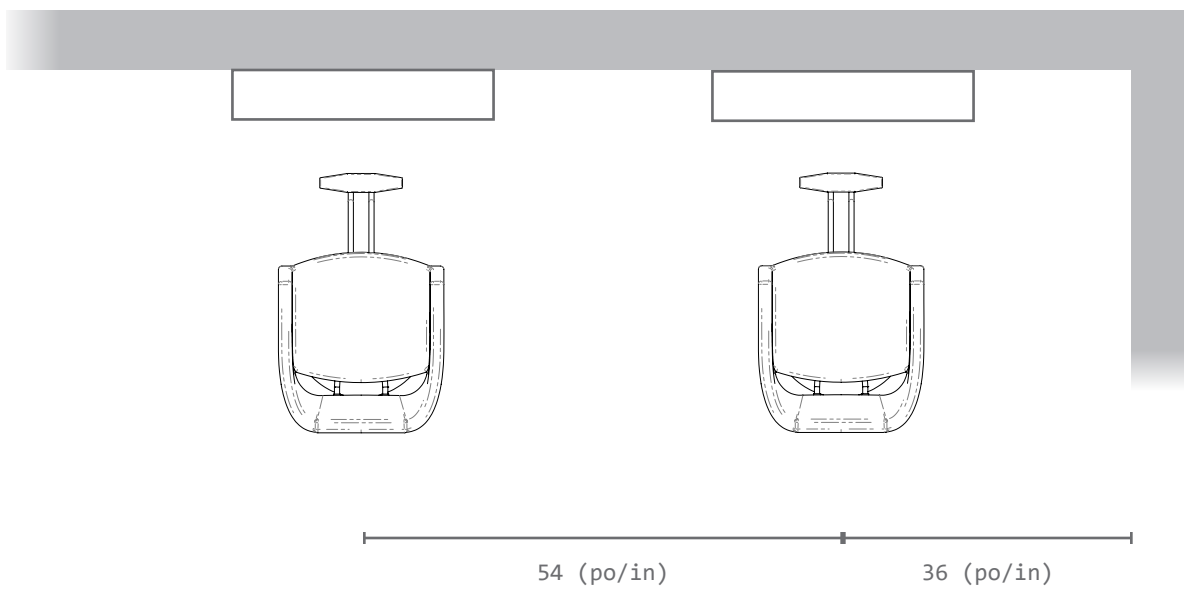
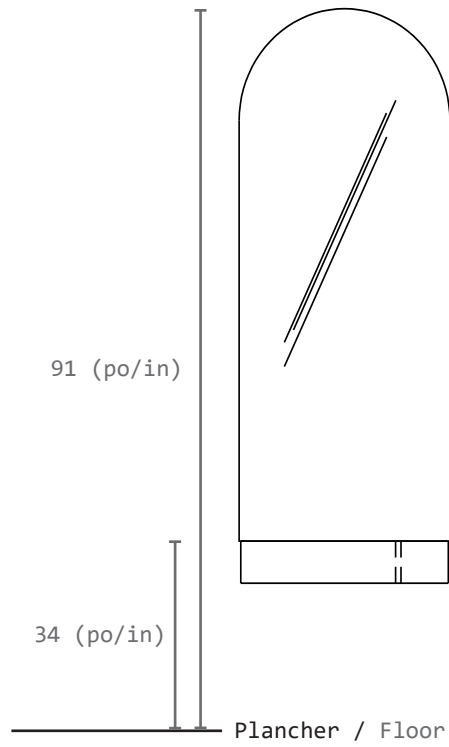

*À titre indicatif / For guidance



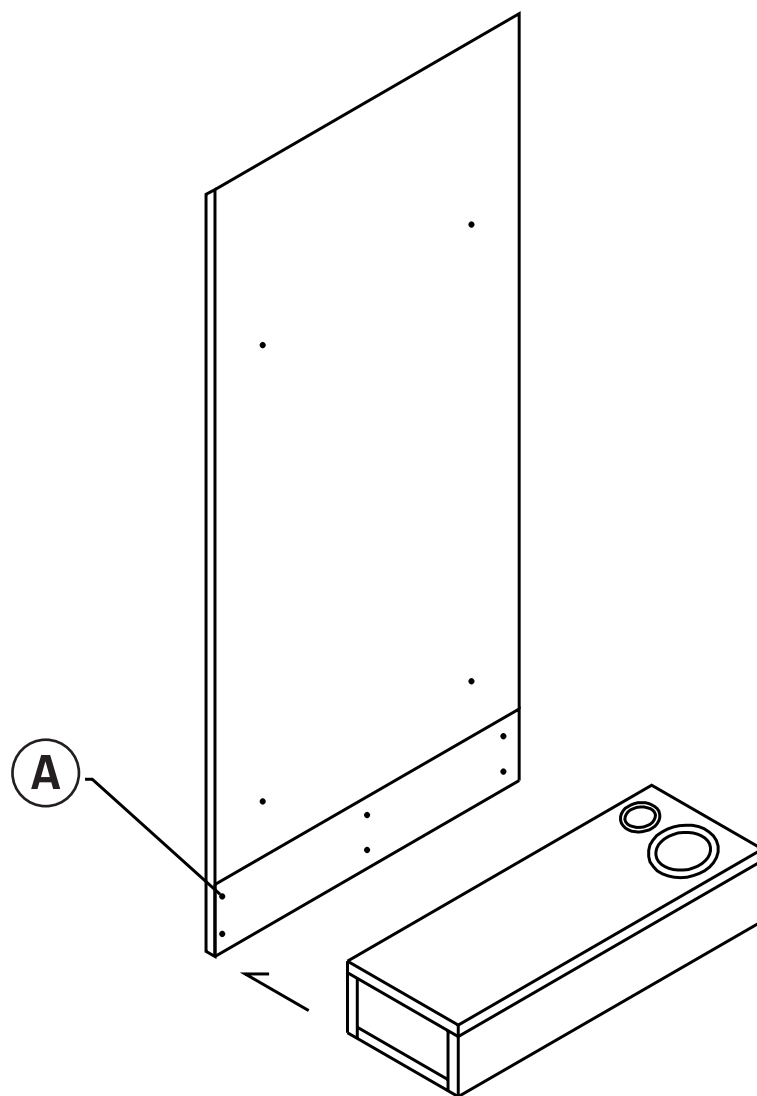

1. Assembler le boîtier au panneau mural à l'aide des 6 boulons / Assemble the box to the mural panel with the 6 bolts



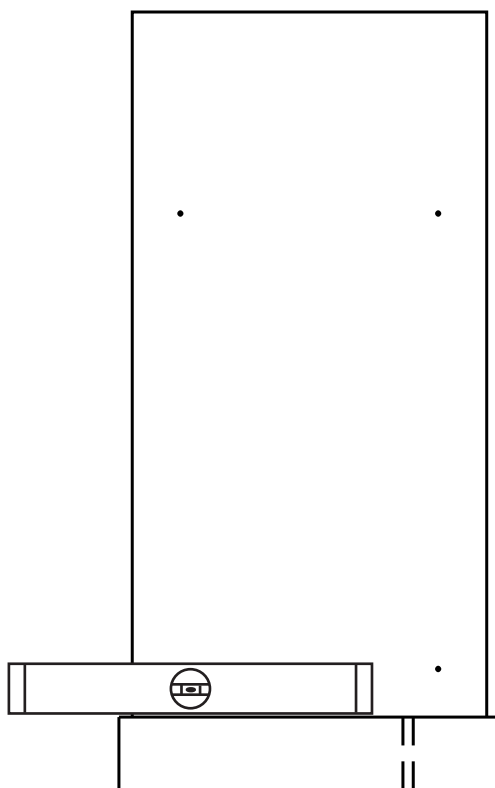

2. Placer la station au mur en prenant soin de la mettre de niveau. Marquer au mur à l'aide d'un crayon à la mine de plomb les endroit pré-perçés de la planche. / Place the station on the wall, taking care to level it. Mark on the wall with a lead pencil the pre-drilled places of the board.



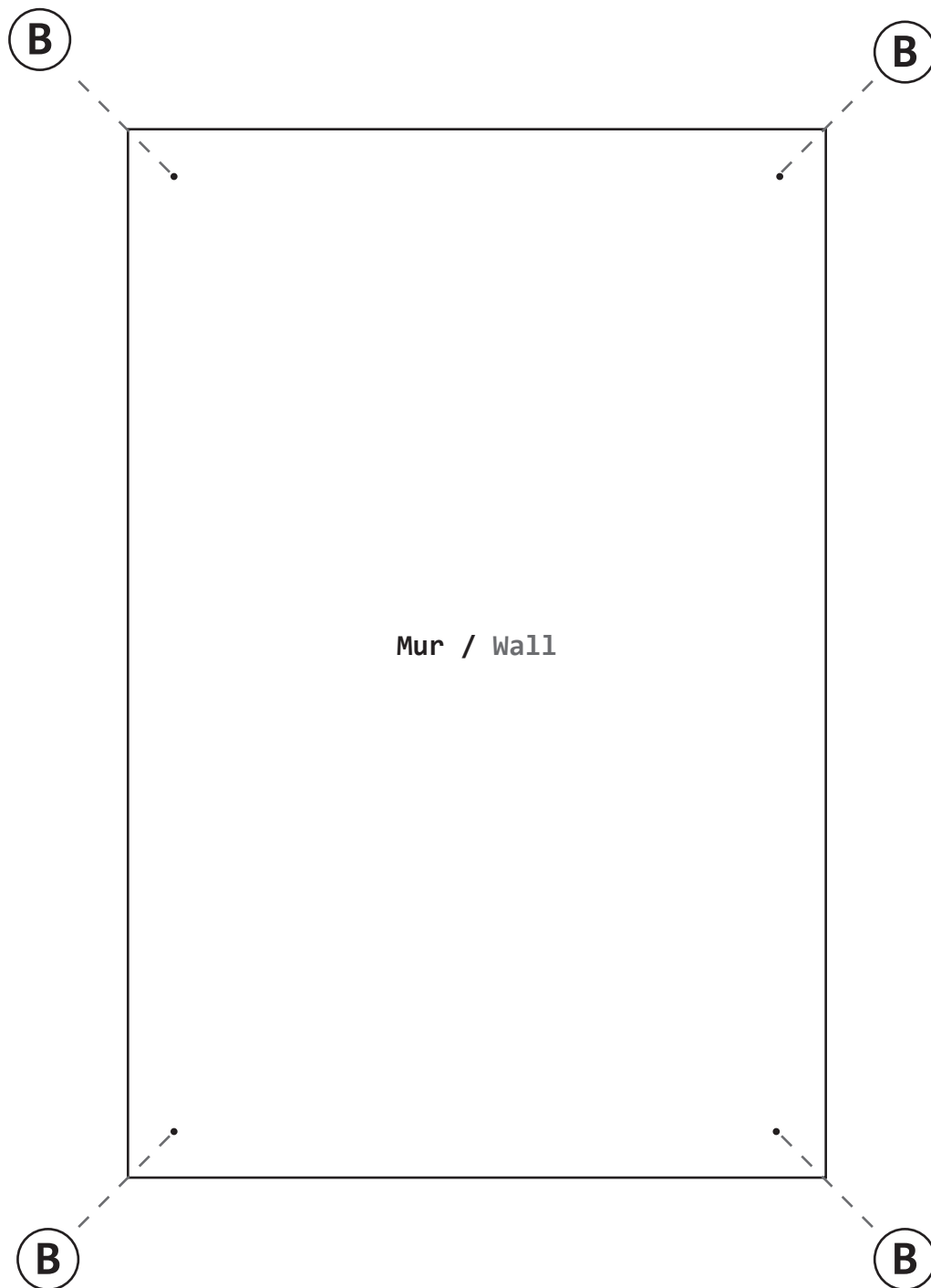

3. Percer à l'aide d'une perceuse avec une mèche du diamètre des ancrages (B). Insérer les ancrages dans les perforations. / Drill using a drill with a bit of the diameter of anchors (B). Insert the anchors in the perforations.



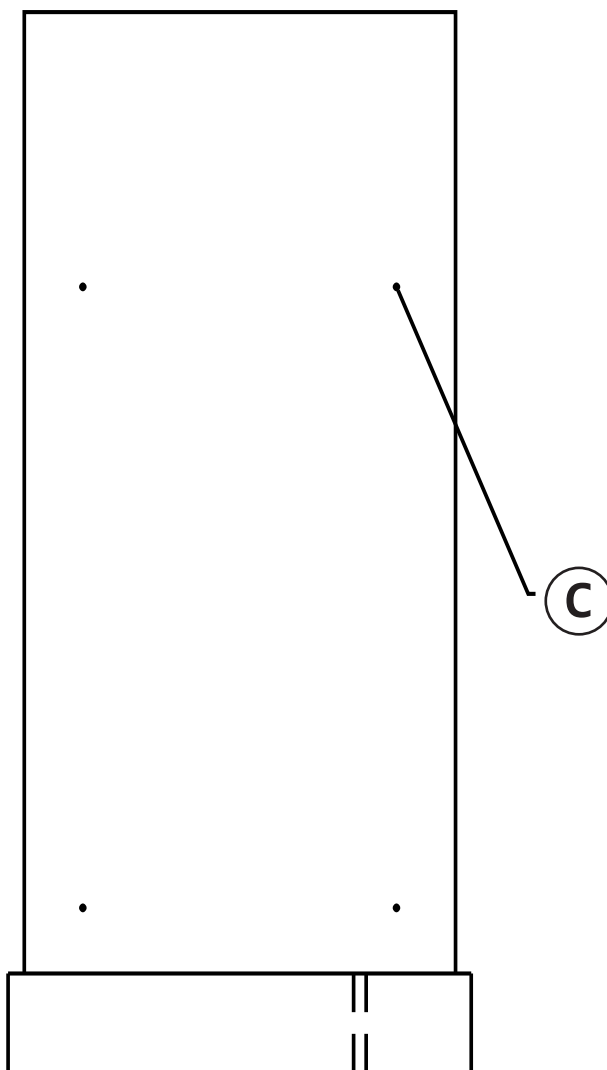

4. Visser la station au mur. / Screw the station to the wall.



Utilisation / Usage

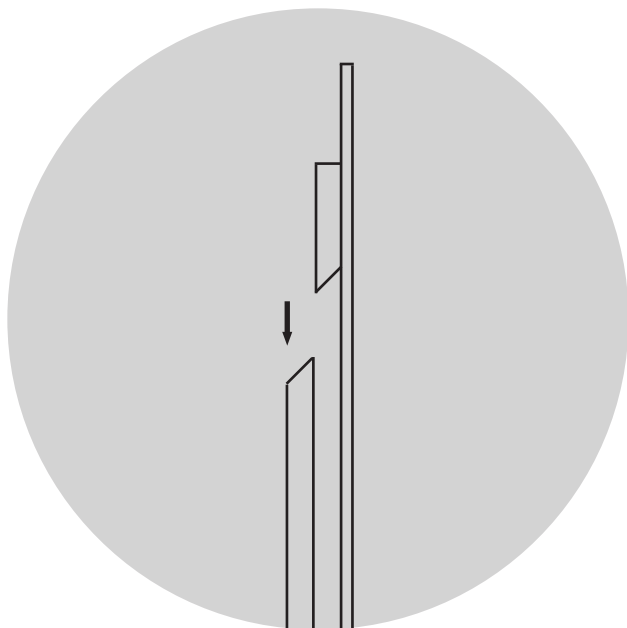

5. Installer et centrer le miroir /
Install and center the mirror

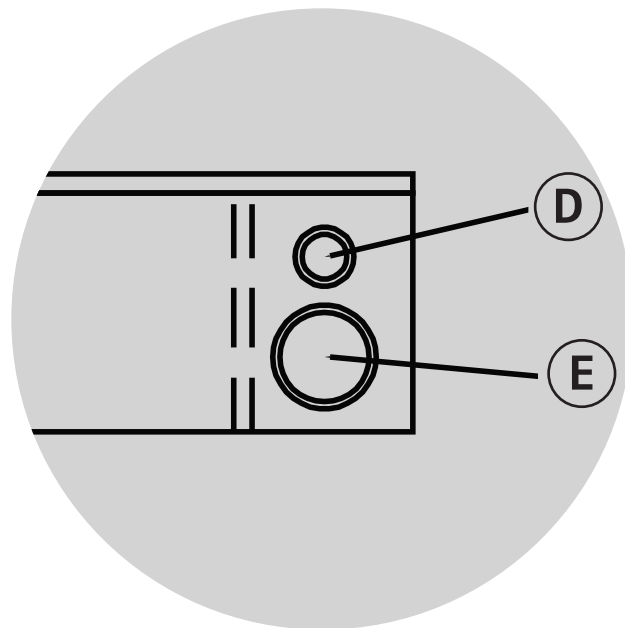

6. Installer les insertions pour
fers et séchoir / Install inserts
for irons and dryer

*Pour une tenue plus durable, nous recommandons de mettre une goutte de silicone transparent 100% naturel entre le panneau et le miroir / For a longer lasting hold, we recommend putting a drop of 100% natural transparent silicone between the panel and the mirror

Entretien / Maintenance



Eau / Water

Savon doux / Soft soap

*Tout type de produit contenant un agent corrosif peut endommager et accélérer la dégradation de cet item /
Any type of product containing a corrosive agent can damage and accelerate the degradation of this item

