

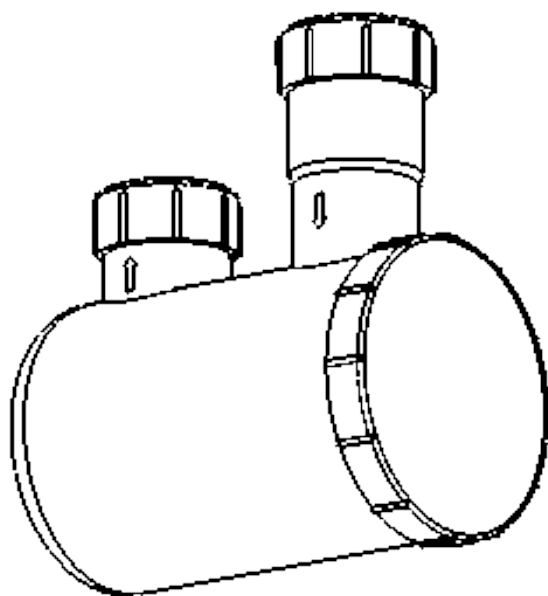

LANVAIN



Intercepteur de cheveux / Hair interceptor

UGS : 616U

Dimensions (pouces / inches)

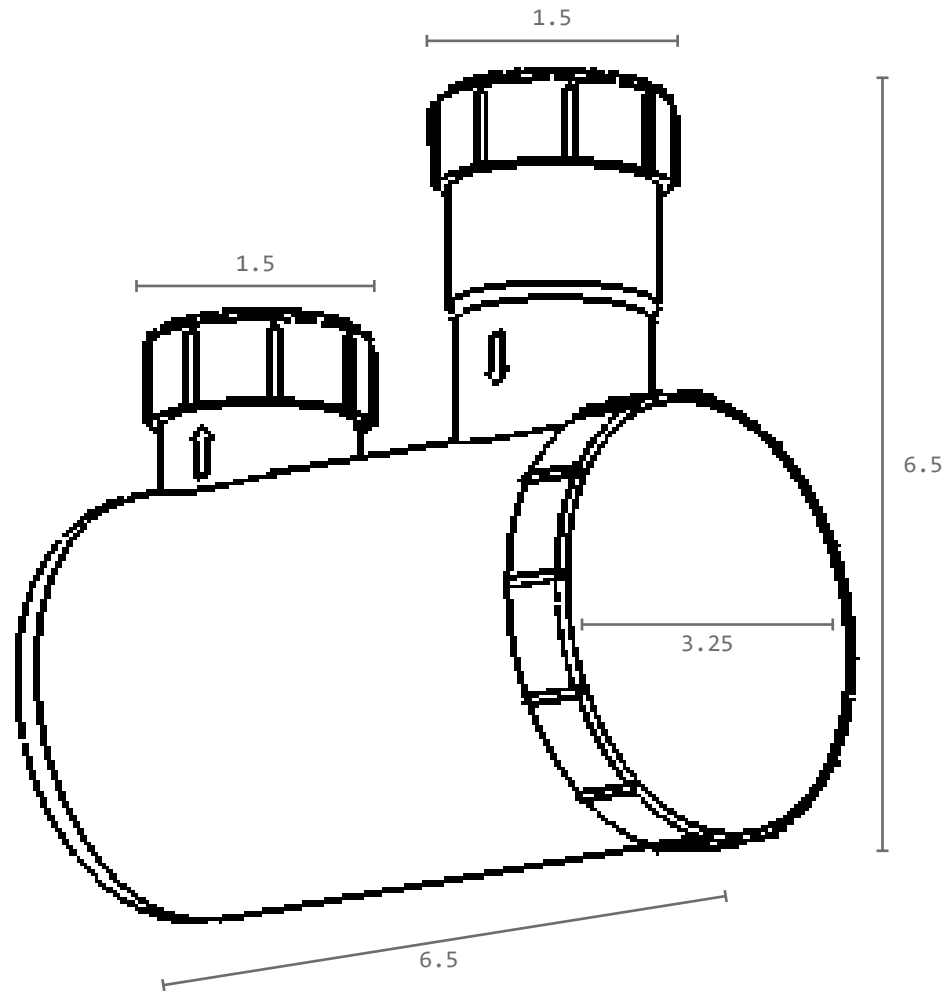

Specifications

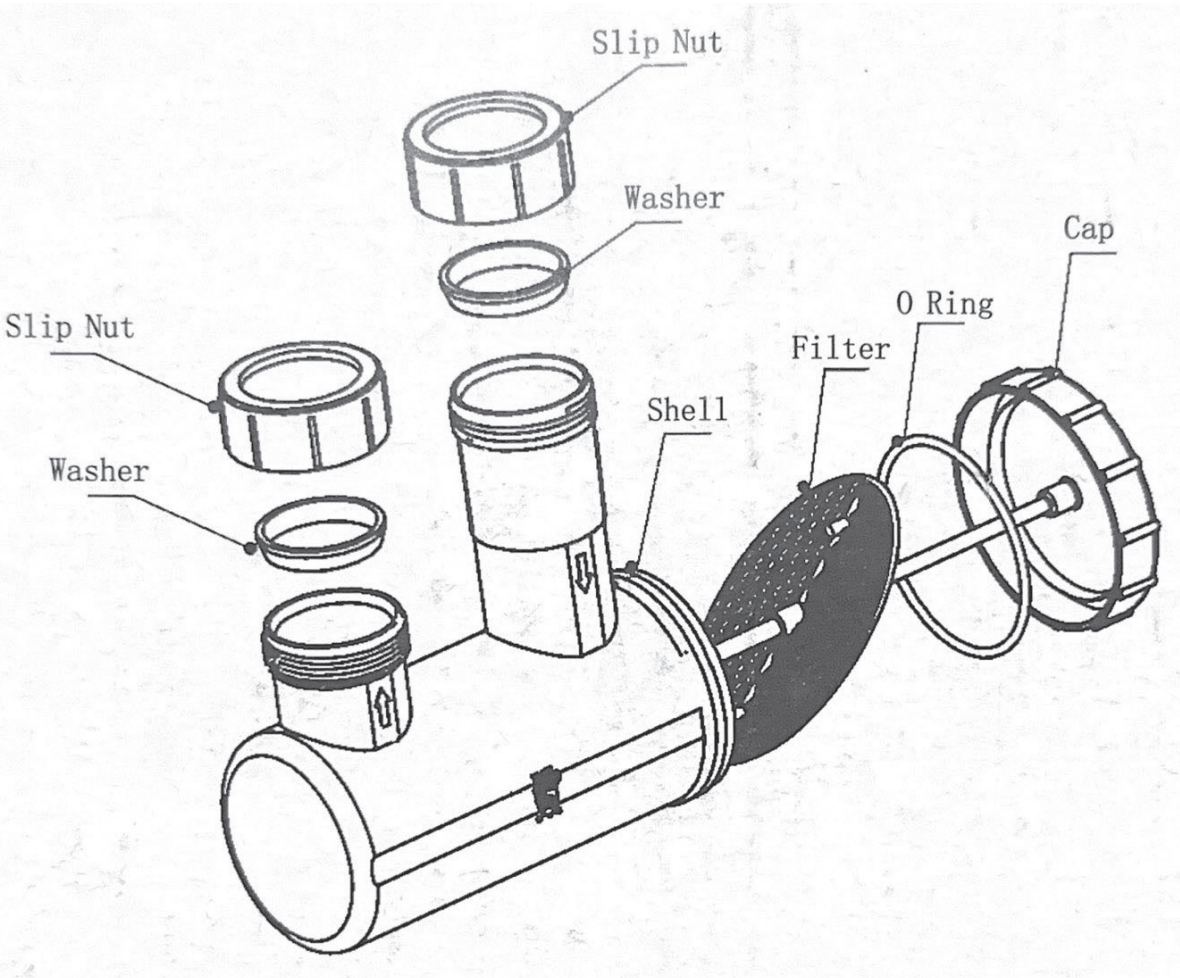

Installation

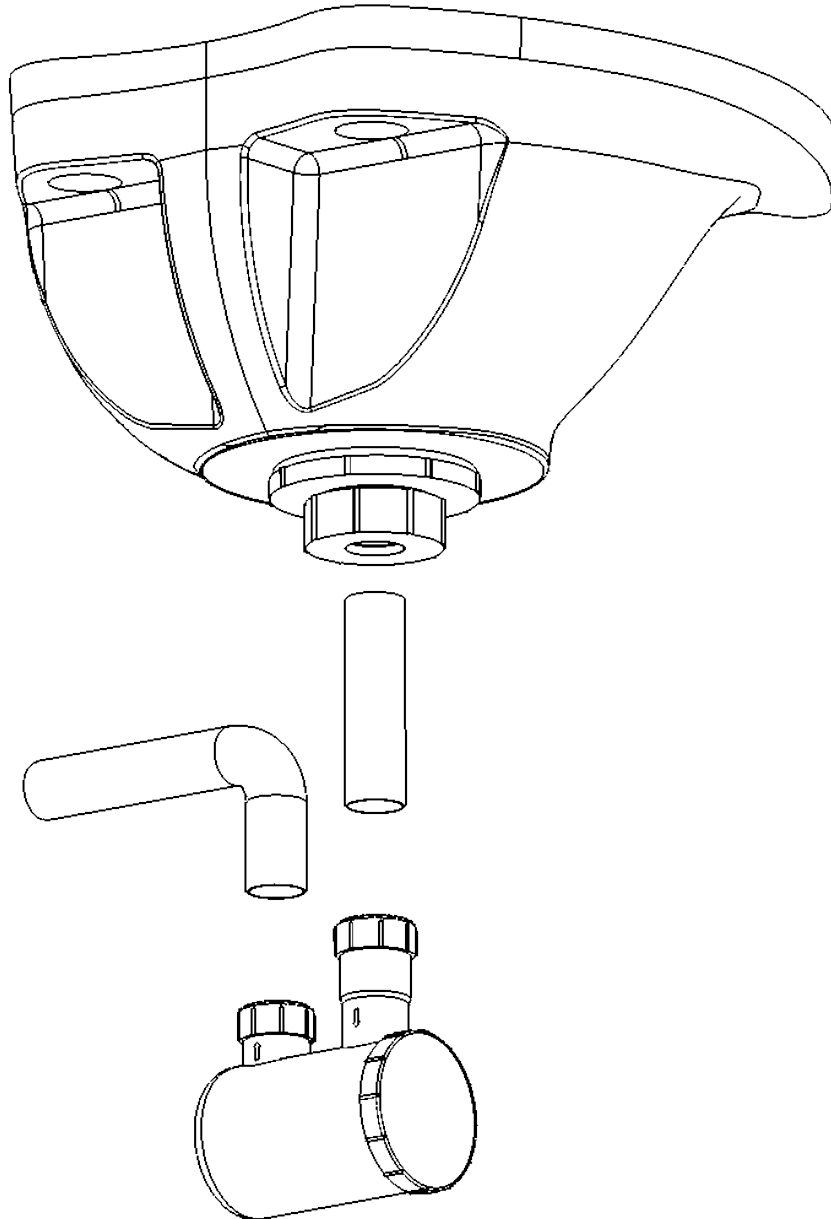

1. Placer l'écrou et la rondelle d'étanchéité sur la pièce de raccordement. Placer ensuite l'autre écrou sur la bride du tuyau coudé. Suivre la direction des flèches dans le sens du renvoi d'eau. /
Place slip nut and washer over tailpiece and place the other slip nut over flange of elbow pipe.
Follow the arrows direction in the direction of the water drainage.

*L'installation doit être fait par un plombier certifié / The installation must be done by a certified plumber



Installation

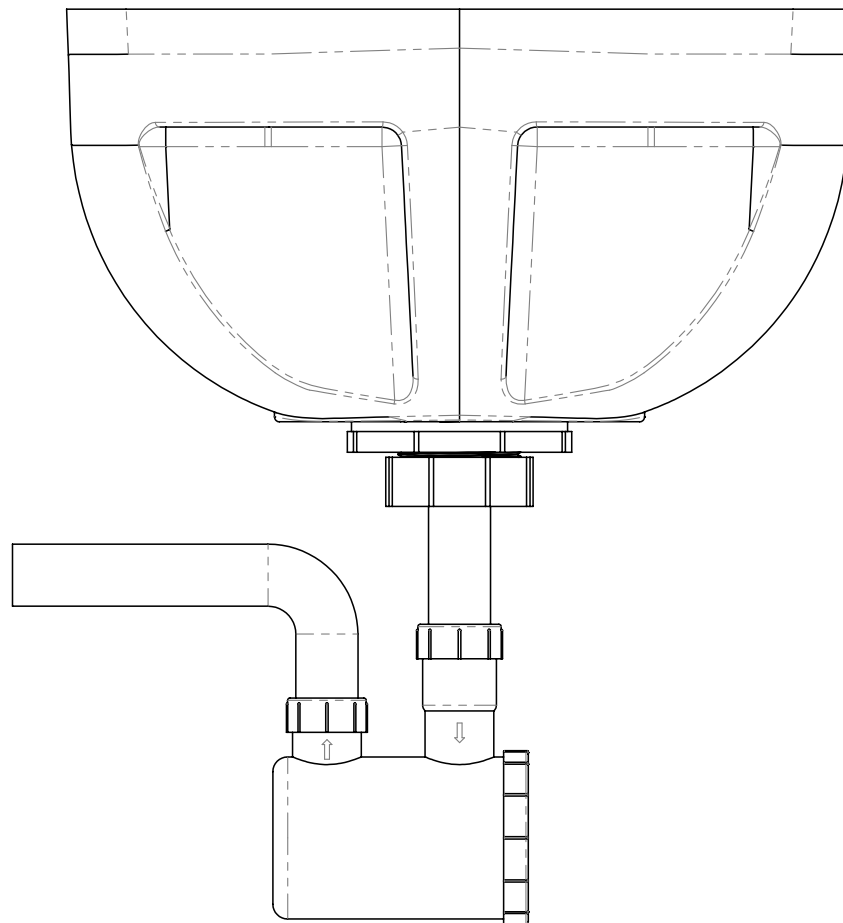

2. Installer l'intercepteur de cheveux et bien serrer les écrous. Faites couler l'eau et vérifié que l'installation est bien étanche. / Install hair interceptor and tighten slip nuts. Run water and check for leaks.

*L'installation doit être fait par un plombier certifié / The installation must be done by a certified plumber



Maintenance

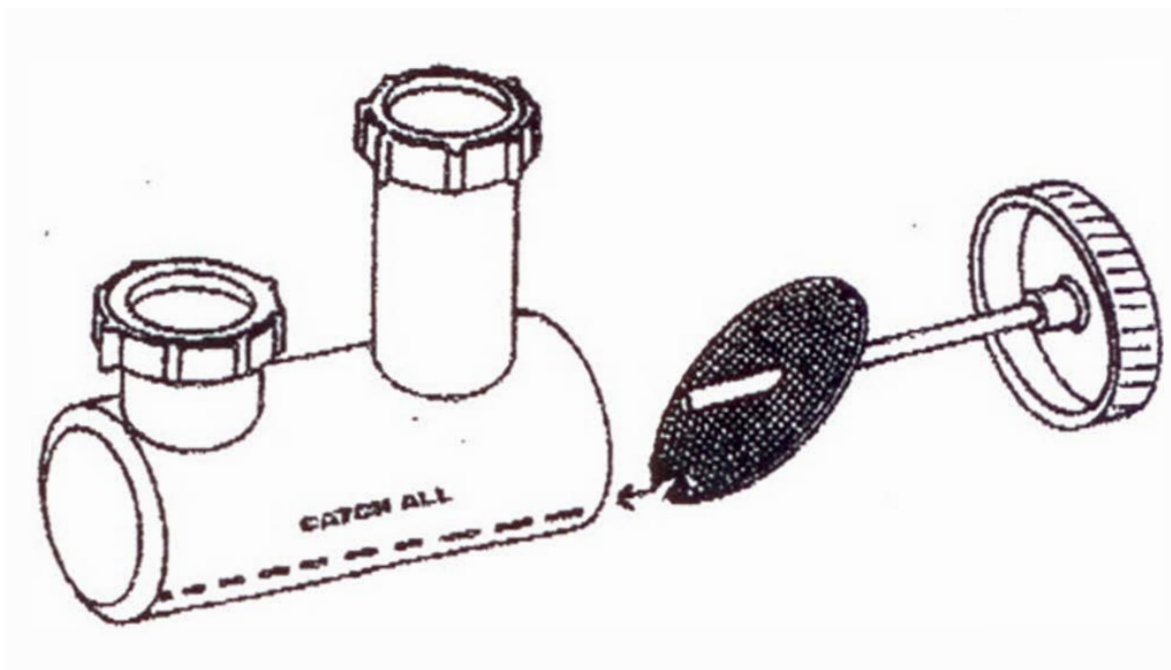

Dévisser le filtre et retirer tous les débris. Assurez-vous que le O-ring est bien positionné dans le capuchon du filtre lorsque vous le refermez. Refermer en s'assurant que le filtre soit dans l'angle présenté sur le dessin ci-haut. / Unscrew the filter and remove any debris. Make sure the O-ring is properly seated in the filter cap when you close it. Close making sure the filter is at the angle shown in the drawing above.

*L'installation doit être fait par un plombier certifié / The installation must be done by a certified plumber





IAPMO R&T Product Listing



This IAPMO R&T Listing is current as of August 27, 2022

File Number:

7930

Product:

Plumbing Fixture Fittings

Products are in compliance with the following code(s):

Uniform Plumbing Code (UPC®)

National Plumbing Code of Canada

Products are certified to the following standard(s):

ASME A112.18.1-2018/CSA B125.1-18





LANVAIN

WHEN ONLY THE BEST WILL DO